



## Roadmap for PCS, the Planetary Camera and Spectrograph for the E-ELT

Markus Kasper<sup>1,a</sup>, Christophe Verinaud<sup>2</sup>, and Dimitri Mawet<sup>3</sup>

<sup>1</sup>ESO, Karl-Schwarzschild-Str. 2, 85748 Garching, Germany

<sup>2</sup>IPAG, 414 Rue de la Piscine, 38400 Saint-Martin d'Hères, France

<sup>3</sup>ESO Vitacura, Alonso de Córdova 3107, Vitacura, Casilla 19001, Santiago de Chile, Chile

**Abstract.** Presently, dedicated instruments at large telescopes (SPHERE for the VLT, GPI for Gemini) are about to discover and explore self-luminous giant planets by direct imaging and spectroscopy. The next generation of 30m-40m ground-based telescopes, the Extremely Large Telescopes, have the potential to dramatically enlarge the discovery space towards older giant planets seen in reflected light and ultimately even a small number of rocky planets. The E-ELT Planetary Camera and Spectrograph (PCS) serves this purpose. Building on the heritage of the EPICS phase-A study, this paper presents revised requirements, a possible concept, and the R&D necessary to realize the instrument.

### 1. Introduction

The Planetary Camera and Spectrograph (PCS) is a potential instrument for the direct imaging and characterization of extra-solar planets with the European ELT (E-ELT). PCS will be optimized for observations in the visible and the near-IR and will have photometric, spectroscopic and polarimetric capabilities.

The E-ELT is currently preparing to go into construction and includes an instrumentation plan with the list of first generation instruments. The choice of instruments will be guided by the high priority scientific objectives as described in “An expanded View of the Universe” [1]. The most prominent science cases selected by the SWG - Exoplanets among them - have been studied as part of the Design Reference Mission (DRM, <http://www.eso.org/sci/facilities/eelt/science/drm/>).

PCS builds upon the heritage of the EPICS (Exoplanet Imaging Camera and Spectrograph) phase-A study, which has been concluded in March 2010 [2]. The goal of this phase-A study was the demonstration of instrument feasibility, derivation of requirements to the E-ELT and its site, and provision of feedback to the DRM.

In the light of recent developments of high performance very small inner working angle coronagraphs for segmented apertures and the overall delayed schedule, the scientific emphasis has shifted from the

---

a e-mail : [mkasper@eso.org](mailto:mkasper@eso.org)

discovery towards the in depth spectroscopic and polarimetric characterization of Exoplanets from Jupiter-like Gas Giants in larger orbits down to rocky planets in very tight orbits ultimately reaching the habitable zone around the late-type M-dwarfs.

## 2. Science context

Most of the nearby Exoplanets will be detected by the radial velocity (RV) down to Earth mass in the HZ for late-type stars and higher mass planets at larger separations up to a few AU or astrometric techniques (e.g. all giant planets up to about 5 AU around nearby stars fainter than 5<sup>th</sup> magnitude with GAIA) in the next decade.

With a projected 1<sup>st</sup> light date beyond 2025, PCS will be ideal for follow-up observations and characterization of the Exoplanets at visible to near-infrared wavelengths. Figure 1 illustrates that PCS will be able to characterize most objects discovered by the other methods. Despite the expected great success of the RV and astrometric techniques in discovering Exoplanets, not a single photon of the planet itself is detected. Hence even the most fundamental physical parameters of the Exoplanets (luminosity and temperature) are unknown, and the information is limited to mass and orbit (with sin-i uncertainty in the case of RV). Hence, it will not be possible to unambiguously demonstrate whether a planet is rocky or whether it resembles Neptune or even a gas giant. Only direct imaging with PCS providing spectral information from the visible to the near-infrared as well as polarimetric information will allow us to characterize the planets and their atmospheres, learn about cloud cover and weather patterns, and ultimately decide whether they may harbor life.

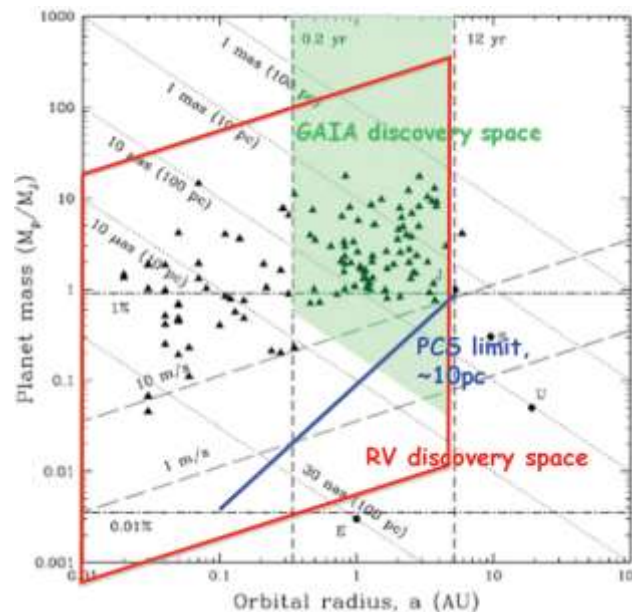

Figure 1. Expected Exoplanet discovery space of GAIA (adapted from [3]), radial velocity, and PCS for a bright nearby star.

The most currently most appealing case is the Earth-size planet orbiting Alpha Centauri B [4]. This planet is seen at an angular separation of 30 mas and a contrast of  $10^{-7}$ , well within the expected capabilities of PCS. A contrast of  $10^{-8}$  would be needed to observe an Earth-size planet in the HZ of a mid M-dwarf at a few tenths of an AU such as Gl 581d [5].

### 3. Instrument requirements

The main observational properties of the nearby target stars are given in the table below.

Table 1. Main properties of PCS target stars.

Spectral type	Apparent Diam. @10pc	$M_I$	$M_J$	Rel. abundance	# visible I<10 & d<20pc
G	~1 mas	~4.2	~3.7	~5%	~40
K	~0.7 mas	~5.5	~4.9	~15%	~100
M	~0.3 mas	~9	~7.5	~80%	~200

Assuming five planets per star, semi-empirical planet mass, size, and mass-period distributions, an albedo of 0.3 (similar to the solar system average), etc. a synthetic Exoplanet population was simulated and is shown in Figure 2. The figure shows that imaging contrasts of the order  $10^{-8}$  must be achieved at very small angular separation of tens of milliarcseconds in order to reach the rocky planets and to observe an Earth-size planet at 0.1 AU (HZ of a mid M-dwarf).

Contrasts of the order  $10^{-9}$  must be achieved beyond 100 mas in order to observe Gas Giants and Neptunes at larger orbital separations (the contrast of Jupiter at 5 AU is about  $10^{-9}$ ).

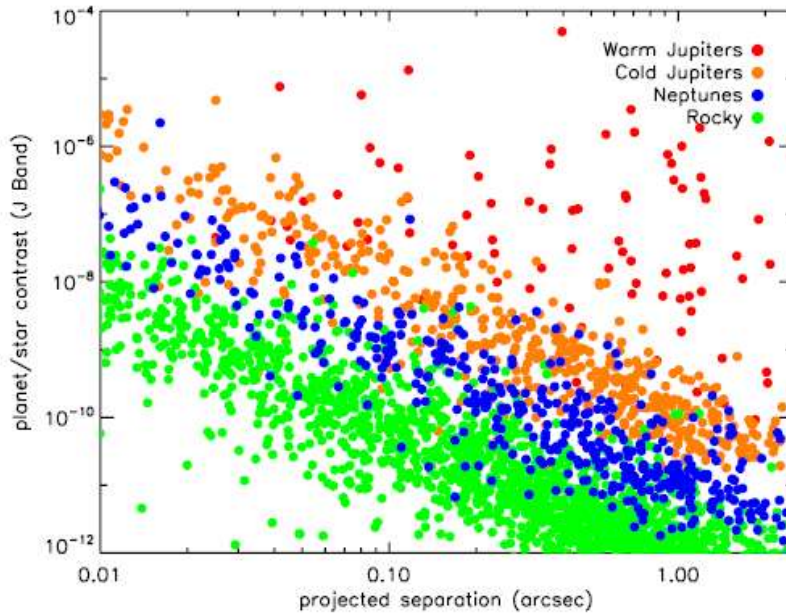

Figure 2. Contrast versus projected separation for a simulated planet population around 600 nearby (distance <20 pc) stars selected from the Hipparcos catalogue. From [6].

The figure, however, does not provide information about whether the actual number of photons received from the planet is sufficient for detection. A crude estimation can be made assuming a XAO-residual halo which is of the order of  $5 \times 10^{-5}$  contrast at smallest angular separations (the next sections will show that this is a reasonable assumption): A  $1\text{-}\sigma$  detection of a  $10^{-8}$  Exoplanet sitting in a  $5 \times 10^{-5}$  halo would require  $5 \times 10^3$  photons. Correspondingly, a  $5\text{-}\sigma$  detection would require  $25 \times 5 \times 10^3 \approx 10^6$  photons. In order to collect that many photons from an Exoplanet in 10 hours with the E-ELT in J-band with 50nm bandwidth and 10% throughput, the Exoplanet must have an apparent magnitude of at least  $J = 26$ . The same brightness limit can be derived by a similar reasoning for a  $10^{-9}$  Exoplanet in a  $5 \times 10^{-6}$  halo (expected XAO residual at 100 mas). For a pure detection where the spectral bandwidth can be larger, the magnitude limit can be somewhat fainter. For such a photon-noise limited contrast

performance the host stars need to be brighter than about  $J = 4-6$  ( $10^{-9}$  are 22.5 mag,  $10^{-8}$  are 20 mag) matching the nearby G and K stars but falling a bit short for an M-star at about 10 pc (see Table 1) for which longer exposure times or larger bandwidth would be needed.

For solar type stars within about 20 pc, the  $10^{-9}$  contrast to observe a giant Exoplanet at 5 AU ( $>0.25''$  at  $<20$  pc) can be reached. Therefore, the high-contrast field of view should be at least of the order  $0.3''-0.4''$  in radius.

#### 4. Conceptual challenges

In order to fulfill the contrast requirements, the general conceptual layout of PCS depicted in Figure 3 is assumed. The seeing limited PSF and contrast will gradually be improved by XAO, non-common path aberration (NCPA) / wave-front control, diffraction control / coronagraphy, and science image post-processing. None of these steps alone is sufficient. High-contrast imaging from the ground encompasses all those disciplines which are to be considered in a system approach.

Starting from final contrast requirements ( $10^{-8}$  @ 15 mas,  $10^{-9}$  @ 100 - 400 mas), we assume that science image post-processing can calibrate quasi-static (life-time similar to observation time) residuals with a precision of about 1% at angular separations larger than about 100 mas and no better than 10% at the inner working angle (IWA) of 15 mas, a raw instrumental PSF contrast better than  $10^{-7}$  (goal  $10^{-8}$ ) must be provided by NCPA and diffraction control system.

XAO residual aberrations cannot be reduced to this level, they will remain at a few times  $10^{-5}$  at 15 mas and  $10^{-6}$  at 100 mas. They are however short-lived, and the contrast will improve with the square-root of time. Coming from  $10^{-5}$ , there is still a long way down to  $10^{-7}$ , and exposure times larger than  $10^4$  times the XAO residual speckle lifetime are needed to average out XAO residuals to the required levels. Reducing the XAO residual speckle lifetime to values below the few seconds provided by a standard temporal filter is therefore an important objective.

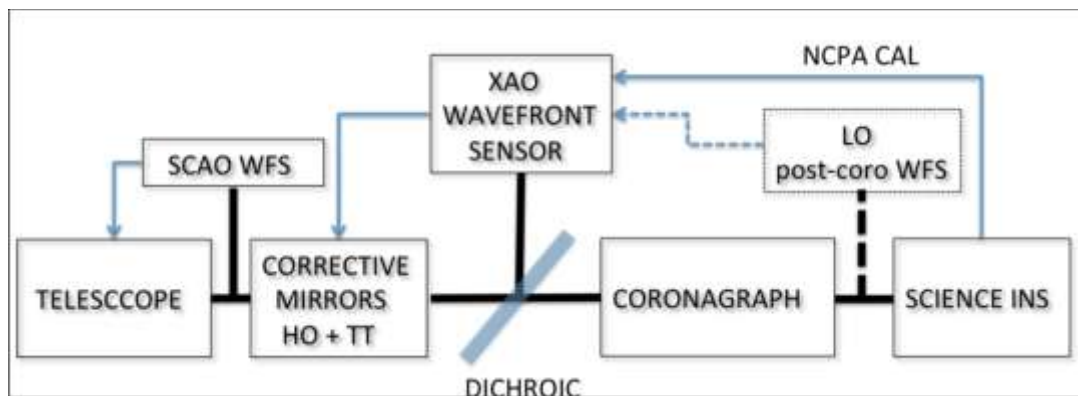

Figure 3: General layout of ELT-PCS high-contrast imaging system

A major update of the PCS concept with respect to the EPICS phase-A consists in the addition of a small angle coronagraph and possibly of a low order post-coronagraph WFS (represented by the dashed line).

##### 4.1. XAO

The first challenge will be the fast loop of the XAO system with its high order WFS and DM. The raw PSF contrast, i.e., the level of XAO-residual speckle halo, should be of the order of  $10^{-5}$  at small angular separations (10-100 mas) in J-H band in order to reduce photon noise to the level required for the observation of rocky planets.

The first parameter to consider is the number of actuators (or equivalently the pitch  $d$  of the actuators as projected on the telescope entrance pupil) of the deformable mirror (DM). The actuator pitch impacts on two variables: i) the maximum Strehl Ratio (SR) measuring the concentration of light in potential planet's signal and ii) the XAO outer Working Angle (OWA) of  $\lambda/(2d)$  which is the largest radial distance at which the DM can correct atmospheric speckles using its maximum spatial frequency (speckles are produced by sinusoidal aberrations at an angular separation from the center proportional to the spatial frequency of the sinusoid).

Figure 4 shows the impact of the individual error terms on the XAO-residual halo assuming the EPICS phase-A assumptions of  $d=0.2$  m leading to  $3 \times 10^4$  actuators and an OWA at 1.3 microns of 0.67 arcsec. The most prominent error source is the temporal bandwidth error due to the finite temporal sampling of the WFS hence the time lag between the application of the DM command and the WFS measurement. It limits the contrast in most of the innermost region with separations less than 100 mas to about  $10^{-5}$ . Other error terms are WFS photon noise (here for a Pyramid sensor), aliasing (can be damped by spatial filter), scintillation, chromaticity of air refractive index (n-chromaticity, different wavelength see slightly different wave-fronts) and chromatic anisoplanatism (different wavelengths take slightly different paths through the atmosphere because of atmospheric refraction, an increasing function of zenith distance). The two last terms are present because the wavelength for WFS is differing from the science wavelength. They are second most important and will limit the performance on bright stars at very small angular separations once the temporal bandwidth error has been reduced.

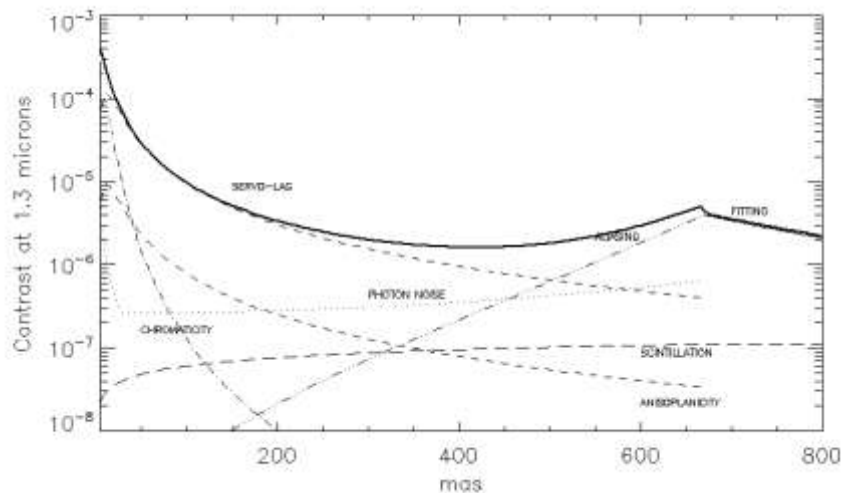

Figure 4: Power spectrum densities for the different AO error sources expressed in terms of contribution to the contrast in the coronagraphic (assumed to be perfect) halo. Servo-lag denotes temporal bandwidth error, chromaticity the refractive index n-chromaticity, and anisoplanaticity denotes the chromatic anisoplanaticity. The solid line represents the sum of all terms. Pyramid sensor 60ph/sub-ap/ms ( $I = 8$  star, 20% transmission) operated at 1 kHz at 900 nm,  $r_0 = 0.133$  m,  $\tau_0 = 4.7$  ms.

Several approaches can achieve a reduction of temporal bandwidth and n-chromaticity errors, most of them requiring further R&D and demonstration:

- Faster frame-rates: This is a straight forward approach to reduce the temporal bandwidth errors. The price to pay is i) increased RON (for non-zero RON detectors) impacting negatively on NGS limiting magnitude and ii) higher demands on RTC computational power. Especially the second point is a severe constraint that requires a complex trade-off between available hardware, WF reconstruction and control algorithms, and degrees of freedom (number of DM actuators and

WFS elements). One possibility to study is to run a high-order XAO loop for Strehl ratio at moderate speed and a low-order loop at high-speed to efficiently correct low spatial frequencies.

- Advanced control laws: Figure 4 considers integrator control, but more advanced control schemes such as double integrators and/or predictive controllers can enhance the overall rejection, in particular the low temporal frequency range, i.e., long-lived aberrations. While such concepts have been developed and studied theoretically, on-sky demonstration is pending.
- n-chromaticity compensation: An obvious way is to sense at a wavelength near the science wavelength. This may, however, be impractical because the science wavelength spans a large range and the required detector technology may not exist (e.g. no CCDs for NIR). Also the red optical part of the spectrum provides highest SNR for XAO wave-front sensing on nearby stars. Since the actual wave-front is known from DM shape and WFS measurement, and the n-chromaticity of the atmosphere is known as well, a viable alternative is the development and test of a special control law which applies RT offsets to the WFS to compensate for n-chromaticity.

## 4.2. PSF contrast

A raw instrumental PSF contrast of the order  $10^{-7}$  (baseline, goal  $10^{-8}$ ) must be provided by the coronagraph and wave-front control system. With a well-balanced error budget and the given XAO residual halo, smooth incoherent light leakage should be no larger than  $10^{-5}$  at 15 mas ( $3 \lambda/D$  at  $1 \mu\text{m}$ ,  $1.8 \lambda/D$  at  $1.6 \mu\text{m}$ ). Such a leakage could for example result from the apparent stellar radii of up to about 0.5 mas ( $= 0.1 \lambda/D$  at  $1 \mu\text{m}$  for the 39-m E-ELT) for small IWA coronagraphs.

### 4.2.1. Coronagraph

The coronagraphic leak due to stellar angular size is incoherent [7] and will not interfere with speckles due to wavefront errors, so the two terms add incoherently in intensity (not amplitude). Hence, this leakage light cannot be calibrated by coherence-based methods and removed by speckle nulling techniques. It is also highly predictable since it is driven by a single parameter (the stellar angular size) and stable in time (assuming the coronagraph pointing is sufficiently stable). Its only contribution to detection limits is the added photon noise. Therefore, coronagraphic leakage due to stellar angular size has a similar effect as the XAO residual halo and should be smaller than  $10^{-5}$  in a well-balanced error budget.

Fast image jitter created e.g. by tip-tilt residuals should be no larger than the stellar angular size in a well-balanced error budget, so no larger than 0.5 mas which sets an important requirement on XAO.

Quasi-static pointing should be very accurate at the level 0.01 mas PTV ( $10^{-3} \lambda/D$  at  $1.6 \mu\text{m}$ ) to achieve the  $<10^{-7}$  PSF residual contrast level at the IWA. A coronagraphic low-order WFS (CLOWFS) was used to control pointing at the  $10^{-3} \lambda/D$  level in a testbed at the Subaru [8]. The PIAA CLOWFS design requires a reflective annular mask in the focal plane that goes well with the PIAA. With phase-mask coronagraphs, a CLOWFS can be realized using the light reflected off the Lyot stop to achieve a similar pointing performance of  $10^{-3} \lambda/D$  [9].

Centrally obscured apertures present a particular challenge for coronagraphy because coronagraphic rejection is approximately limited by the area ratio between the central obscuration and the full aperture. However, the impact of a centrally obscured aperture without further fine structure can be strongly mitigated by the PIAA [10] through optical re-mapping, and by the vortex coronagraph through shaped pupil apodization [11], or annular apodization [12], see Figure 5.

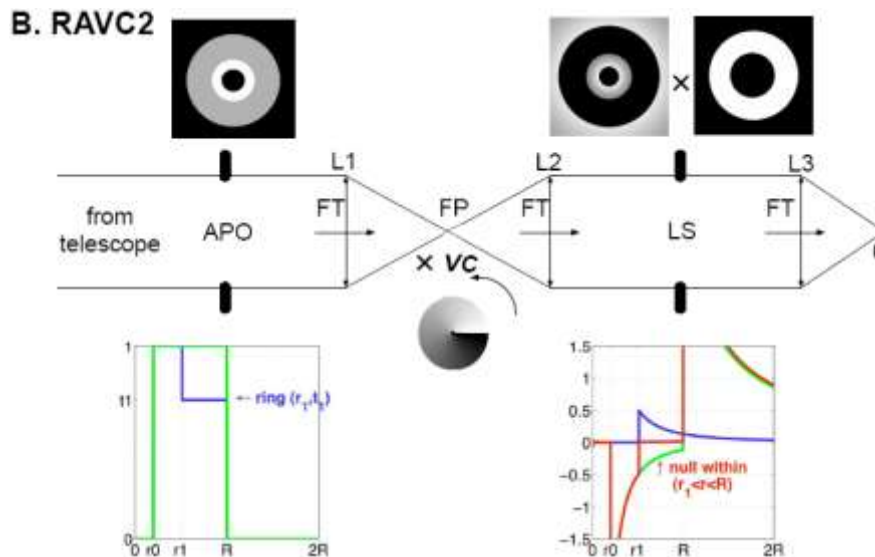

Figure 5. RAVC of topological charge 2. The ring of radius  $r_1$  and amplitude transmittance  $t_1$  is optimized so that the overlap of the self-similar vortex functions at the Lyot plane issued from the central obscuration (green curve) and the ring (blue curve) perfectly cancel each other between  $r_1$  and  $R$  (red curve). From [12].

Secondary mirror spiders produce extended spike-shaped features, and the net-like gap structure of a segmented mirror produces a regular speckle pattern with a pitch that is inversely proportional to the segment pitch. An efficient diffraction control system has to take aperture irregularities into account. Conventional Apodizers have been calculated for irregular apertures [13], and are now optimized to deal with phase mask coronagraphs.

Among the small IWA coronagraphs, two solutions emerged as being the most efficient in terms of useful throughput, and sensitivity to low-order aberrations: the phase induced amplitude apodization complex mask (PIAACMC) [14] and the Vortex coronagraph (VC) [15] families. Vigorous R&D is currently on-going with new solutions emerging, pointing hybridization of pupil plane and focal plane phase/amplitude modulations. The goal is to render the irregular shaped and centrally obscured apertures friendlier to focal plane mask, allowing them to perform nominally.

PCS R&D will aim at the demonstration of a small IWA apodized VVC and/or PIAACMC. First it is planned to carry out a numerical study to derive a suitable apodizer for a VVC with topological charge 4 for an irregular aperture representative of the E-ELT one and predict its performance and source size leakage. Then, a validation of this VVC and possibly a PIAACMC in the laboratory is foreseen.

#### 4.2.2. Wavefront control

Besides the efficient coronagraph, a wavefront control system is needed to reduce quasi-static speckles, e.g. produced by instrument aberrations, to the required level of  $10^{-7}$  (goal  $10^{-8}$ ) and to maintain this level during the observation in the presence of turbulence residuals and photon noise.

Many approaches to use speckle coherence for wavefront sensing exist. Most commonly used is a method where a fraction of coherent light from the star is spread over some area by some probe phase aberration introduced by the DM. Since the corresponding complex amplitude in the focal plane is known, the way it interferes with the coherent speckles provides the required information. Such focal plane wavefront sensing (FPWS) methods have been implemented successfully at the FFREE bench at IPAG and HOT at ESO. Most FPWS method does not need specific hardware and is not linked to a particular type of coronagraph. So far, FPWS has been used in an iterative closed loop speckle nulling

scheme on rather high SNR QSS, and it remains to be demonstrated for PCS that it can work well enough in a noisy environment of XAO residual turbulence and for absolute measurements.

## 5. Conclusions

PCS will be a versatile EELT instrument for the characterization of Exoplanets down to Earth-mass, the detection of bio-signatures of M-star HZ planets, and the detection and study of forming planets. The instrument concept and technological choices are advanced, but still their technological readiness levels need to be raised above the laboratory test level in a relevant environment (~TRL 6) or higher.

The XAO system (high order DM, drive electronics and RTC) is the largest cost driver of PCS and also presents the largest technological risk. Deformable mirrors and drive electronics scale approximately linearly with number of actuators, while the RTC even scales with the square of it for a standard matrix-vector-reconstruction of the control signal. A detailed numerical study to derive the minimum number of DM actuators to fulfill the XAO residual error and contrast requirements in a relevant environment (E-ELT geometry) is therefore another crucial activity to manage the technological readiness of PCS.

All these activities call for a significant investment in a 3-5 years R&D programme before PCS can go into the construction phase. Assuming that the construction phase would last 8-10 years, the characterization of Exoplanet by direct imaging with the E-ELT could start around 2028.

## 6. References

1. An Expanded View of the Universe: Science with the E-ELT, ESO Munich (2010)
2. M. Kasper et al., Proc. SPIE, 7735, pp.9 (2010)
3. M. Perryman et al., ESO-ESA working group on "Extra-solar Planets" (2005)
4. X. Dumusque et al., Nature, **491**, p. 207-211 (2012)
5. F. Selsis et al., A&A, **476**, pp. 1372 (2007)
6. M. Bonavita et al., A&A, **537**, pp. 67 (2012)
7. O. Guyon et al., ApJS, **167**, pp. 81 (2007)
8. O. Guyon et al., ApJ, **693**, pp. 75 (2009)
9. G. Singh et al., Proc. AO4ELT3 (2013)
10. O. Guyon, A&A, **494**, pp.379 (2003)
11. A. Carlotti, A&A, **551**, pp. 10 (2013)
12. D. Mawet et al., arXiv 1309.3328 (2013)
13. A. Carlotti et al., arXiv 1108.4050 (2011)
14. O. Guyon et al., ApJS, **190**, pp. 220 (2010)
15. D. Mawet et al., ApJ, **633**, pp. 1191 (2005)